**Fasteners — Button head screws with
reduced loadability —**

**Part 2:
Hexagon socket button head screws
with collar**

*Fixations — Vis à tête cylindrique bombée plate à capacité de charge
réduite —*

*Partie 2: Tête cylindrique bombée plate à six pans creux et à embase
plate*



COPYRIGHT PROTECTED DOCUMENT

© ISO 2022

All rights reserved. Unless otherwise specified, or required in the context of its implementation, no part of this publication may be reproduced or utilized otherwise in any form or by any means, electronic or mechanical, including photocopying, or posting on the internet or an intranet, without prior written permission. Permission can be requested from either ISO at the address below or ISO's member body in the country of the requester.

ISO copyright office
CP 401 • Ch. de Blandonnet 8
CH-1214 Vernier, Geneva
Phone: +41 22 749 01 11
Email: copyright@iso.org
Website: www.iso.org

Published in Switzerland

Contents

	Page
Foreword	iv
1 Scope	1
2 Normative references	1
3 Terms and definition	2
4 Dimensions	2
5 Requirements and reference International Standards	6
6 Marking and labelling	7
6.1 Marking on product.....	7
6.2 Labelling on package.....	7
7 Designation	7
Bibliography	8

Foreword

ISO (the International Organization for Standardization) is a worldwide federation of national standards bodies (ISO member bodies). The work of preparing International Standards is normally carried out through ISO technical committees. Each member body interested in a subject for which a technical committee has been established has the right to be represented on that committee. International organizations, governmental and non-governmental, in liaison with ISO, also take part in the work. ISO collaborates closely with the International Electrotechnical Commission (IEC) on all matters of electrotechnical standardization.

The procedures used to develop this document and those intended for its further maintenance are described in the ISO/IEC Directives, Part 1. In particular, the different approval criteria needed for the different types of ISO documents should be noted. This document was drafted in accordance with the editorial rules of the ISO/IEC Directives, Part 2 (see www.iso.org/directives).

Attention is drawn to the possibility that some of the elements of this document may be the subject of patent rights. ISO shall not be held responsible for identifying any or all such patent rights. Details of any patent rights identified during the development of the document will be in the Introduction and/or on the ISO list of patent declarations received (see www.iso.org/patents).

Any trade name used in this document is information given for the convenience of users and does not constitute an endorsement.

For an explanation of the voluntary nature of standards, the meaning of ISO specific terms and expressions related to conformity assessment, as well as information about ISO's adherence to the World Trade Organization (WTO) principles in the Technical Barriers to Trade (TBT), see www.iso.org/iso/foreword.html.

This document was prepared by Technical Committee ISO/TC 2, *Fasteners*, Subcommittee SC 11, *Fasteners with metric external thread*, in collaboration with the European Committee for Standardization (CEN) Technical Committee CEN/TC 185, *Fasteners*, in accordance with the Agreement on technical cooperation between ISO and CEN (Vienna Agreement).

This second edition cancels and replaces the first edition (ISO 7380-2:2011), which has been technically revised.

The main changes are as follows:

- the whole standard (including title) has been improved to clearly point out that these hexagon socket button head screws have reduced loadability because of their head design (head dimensions and penetration of the hexagon socket);
- the reference thread length b has been increased to $3d$ for partially threaded screws M16 so that these screws can be tensile tested in accordance with ISO 3506-1 ($b \geq 3d$ is required to tensile test screws with reduced loadability);
- the reference datum for the outer diameter of the bearing face has been specified (see [Figure 1](#)), and the minimum values have been reduced to $d_{w,\min} = d_{c,\min} \times 0,9$ considering the manufacturing aspects for "button head with collar" (see [Table 1](#));
- e_{\min} values have been rounded to two decimal places (see [Table 1](#));
- the maximum depth of the hexagon socket t_{\max} has been added (see [Table 1](#));
- symbol w has been substituted by the new symbol w_b in order to define the wall thickness between the bottom of the cylindrical broached hole and the bearing face (see [Figure 2](#) and [Table 1](#));
- the definition of r_f in [Figure 1](#) has been changed to allow the offset of the centre of the radius from the thread axis;
- the smallest and greatest standard lengths have been amended (see [Table 2](#));

- the minimum ultimate tensile loads were recalculated and have been changed to more precise values for screws with property classes 8.8 (M5, M12 and M16) and 10.9 (M3, M6 and M10), see [Table 4](#);
- specifications for marking and labelling have been added as new [Clause 6](#).

A list of all parts in the ISO 7380 series can be found on the ISO website.

Any feedback or questions on this document should be directed to the user's national standards body. A complete listing of these bodies can be found at www.iso.org/members.html.

Fasteners — Button head screws with reduced loadability —

Part 2:

Hexagon socket button head screws with collar

1 Scope

This document specifies the characteristics of hexagon socket button head screws with collar, with reduced loadability due to head design, in steel, with metric coarse pitch threads M3 to M16, and with product grade A.

If in certain cases other specifications are requested, dimensional options can be selected from ISO 888 or ISO 4753.

NOTE The reduced loadability (related to the head dimensions in combination with penetration of the hexagon socket specified in this document) implies a limitation of ultimate tensile load shown by a specific marking (property class preceded by a zero). The loadability in the head is assumed to be 80 % of that in the thread for all sizes and all property classes, see [Table 4](#).

2 Normative references

The following documents are referred to in the text in such a way that some or all of their content constitutes requirements of this document. For dated references, only the edition cited applies. For undated references, the latest edition of the referenced document (including any amendments) applies.

ISO 225, *Fasteners — Bolts, screws, studs and nuts — Symbols and descriptions of dimensions*

ISO 888, *Fasteners — Bolts, screws and studs — Nominal lengths and thread lengths*

ISO 898-1, *Mechanical properties of fasteners made of carbon steel and alloy steel — Part 1: Bolts, screws and studs with specified property classes — Coarse thread and fine pitch thread*

ISO 965-1, *ISO general purpose metric screw threads — Tolerances — Part 1: Principles and basic data*

ISO 1891-4, *Fasteners — Vocabulary — Part 4: Control, inspection, delivery, acceptance and quality*

ISO 3269, *Fasteners — Acceptance inspection*

ISO 4042, *Fasteners — Electroplated coating systems*

ISO 4753, *Fasteners — Ends of parts with external ISO metric thread*

ISO 4759-1, *Tolerances for fasteners — Part 1: Bolts, screws, studs and nuts — Product grades A, B and C*

ISO 6157-1, *Fasteners — Surface discontinuities — Part 1: Bolts, screws and studs for general requirements*

ISO 8991, *Designation system for fasteners*

ISO 8992, *Fasteners — General requirements for bolts, screws, studs and nuts*

ISO 10683, *Fasteners — Non-electrolytically applied zinc flake coating systems*

3 Terms and definition

No terms and definitions are listed in this document.

ISO and IEC maintain terminology databases for use in standardization at the following addresses:

- ISO Online browsing platform: available at <https://www.iso.org/obp>
- IEC Electropedia: available at <https://www.electropedia.org/>

4 Dimensions

Dimensions shall be in accordance with [Figures 1 to 3](#) and with [Tables 1 and 2](#).

Symbols and descriptions of dimensions are specified in ISO 225.

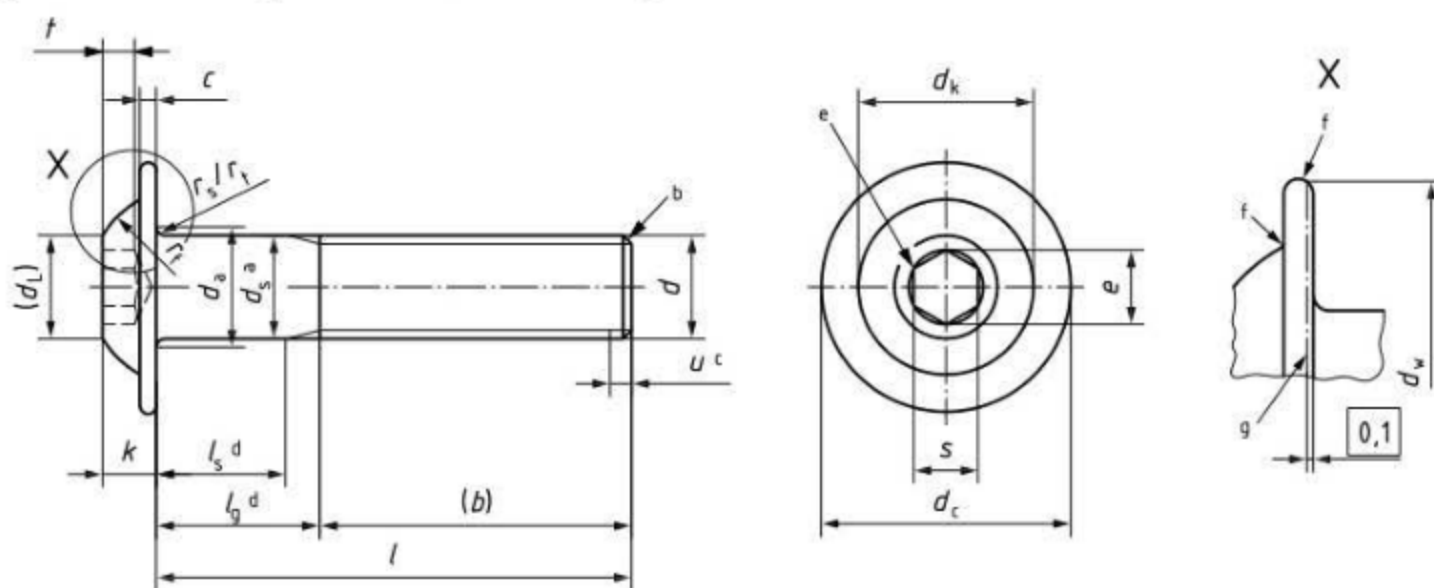

- r_s underhead radius for screws with unthreaded shank
- r_t underhead radius for fully threaded screws
- a d_s specified in [Table 1](#) only applies if $l_{s,min}$ is specified in [Table 2](#).
- b In accordance with ISO 4753: chamfered end (CH), but for sizes $\leq M4$ as rolled end (RL) is also allowed.
- c Incomplete thread $u \leq 2P$.
- d $l_{g,max} = l_{nom} - b$ and $l_{s,min} = l_{g,max} - 5P$.
- e A slight rounding or countersink at the mouth of the socket is permissible.
- f Contour at the discretion of the manufacturer.
- g Reference datum for d_w .

Figure 1 — Hexagon socket button head screws with collar

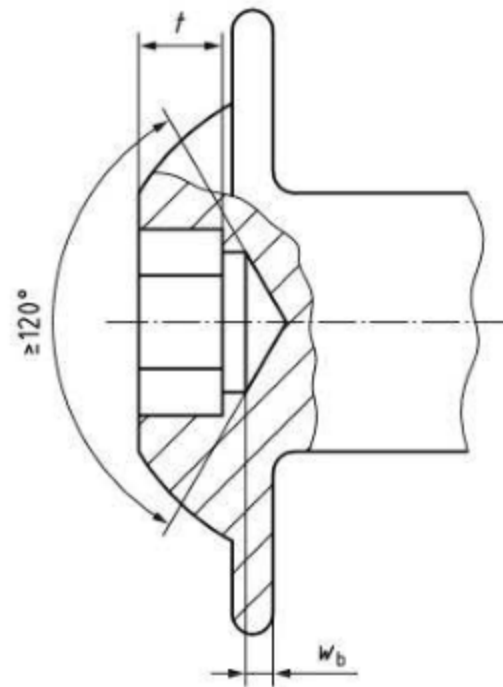

w_b wall thickness between the bottom of the cylindrical hole and bearing face

Figure 2 — Permissible alternative form of socket (broached socket)

For broached sockets which are at the maximum limit of size, the overcut resulting from drilling shall not exceed 1/3 of the length of any flat of the socket which is $e/2$ (see [Figure 3](#)).

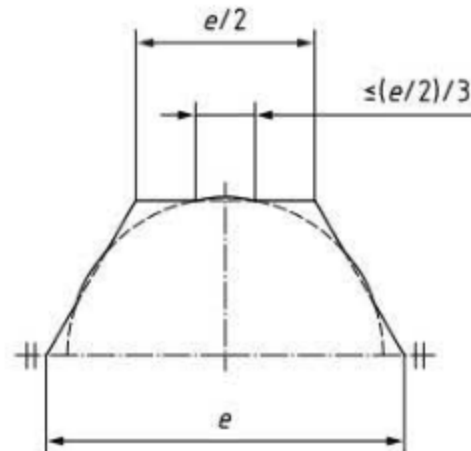

Figure 3 — Detail: Broached socket

Table 1 — Dimensions of hexagon socket button head screws with collar

Dimensions in millimetres

Thread, d		M3	M4	M5	M6	M8	M10	M12	M16
p^a		0,5	0,7	0,8	1	1,25	1,5	1,75	2
c	max.	0,7	0,8	1,0	1,2	1,5	2,0	2,4	2,8
	min.	0,55	0,65	0,80	1,00	1,25	1,70	2,10	2,50
d_a	max.	3,6	4,7	5,7	6,8	9,2	11,2	13,7	17,7
d_c	max.	6,9	9,4	11,8	13,6	17,8	21,9	26,0	34,0
	min.	6,32	8,82	11,10	12,90	17,10	21,06	25,16	33,00
d_k	max.	5,20	7,20	8,80	10,00	13,20	16,50	19,40	26,00
	min.	4,90	6,84	8,44	9,64	12,77	16,07	18,88	25,48
d_L	ref.	2,6	3,8	5,0	6,0	7,7	10,0	12,0	16,0
d_s^b	max.	3,00	4,00	5,00	6,00	8,00	10,00	12,00	16,00
	min.	2,86	3,82	4,82	5,82	7,78	9,78	11,73	15,73
d_w^c	min.	5,69	7,94	9,99	11,61	15,39	18,95	22,64	29,70
e^d	min.	2,30	2,87	3,44	4,58	5,72	6,86	9,15	11,43
k	max.	1,65	2,20	2,75	3,30	4,40	5,50	6,60	8,80
	min.	1,40	1,95	2,50	3,00	4,10	5,20	6,24	8,44
r_f	max.	3,70	4,60	5,75	6,15	7,95	9,80	11,20	15,30
	min.	3,30	4,20	5,25	5,65	7,45	9,20	10,50	14,50
r_s	min.	0,10	0,20	0,20	0,25	0,40	0,40	0,60	0,60
r_t	min.	0,30	0,40	0,45	0,50	0,70	0,70	1,10	1,10
s^d	nom.	2	2,5	3	4	5	6	8	10
	max.	2,080	2,580	3,080	4,095	5,140	6,140	8,175	10,175
	min.	2,020	2,520	3,020	4,020	5,020	6,020	8,025	10,025
t	max. ^e	1,20	1,65	2,12	2,26	3,05	3,75	4,61	6,19
	min.	1,04	1,30	1,56	2,08	2,60	3,12	4,16	5,20
w_b	min.	0,20	0,30	0,38	0,74	1,05	1,45	1,63	2,25

^a P is the pitch of the thread.

^b d_s only applies if $l_{s,min}$ is specified in [Table 2](#).

^c $d_{w,min} = 0,90d_{c,min}$

^d For combined gauging of socket dimensions, e and s , see ISO 23429.

^e $t_{max} = k_{min} - w_{b,min}$

Table 2 — Lengths

Dimensions in millimetres

Thread, <i>d</i>			M3	M4	M5	M6	M8	M10	M12	M16																
<i>b</i> ^a ref.			18	20	22	24	28	32	36	48																
<i>l</i>			Range of standard lengths between the stepped bold lines (white area)																							
			Shank length <i>l_s</i> and grip length <i>l_g</i> ^b																							
nom.	min.	max.	<i>l_s</i> min.	<i>l_g</i> max.	<i>l_s</i> min.	<i>l_g</i> max.	<i>l_s</i> min.	<i>l_g</i> max.	<i>l_s</i> min.	<i>l_g</i> max.	<i>l_s</i> min.	<i>l_g</i> max.	<i>l_s</i> min.	<i>l_g</i> max.	<i>l_s</i> min.	<i>l_g</i> max.	<i>l_s</i> min.	<i>l_g</i> max.								
6	5,76	6,24	Screws with too short length																							
8	7,71	8,29																								
10	9,71	10,29																								
12	11,65	12,35																								
16	15,65	16,35																								
20	19,58	20,42																								
25	24,58	25,42	4,5	7,0	Fully threaded screws ^c																					
30	29,58	30,42	9,5	12,0																			6,5	10,0	4,0	8,0
35	34,5	35,5	Length by agreement in accordance with ISO 888		11,5	15,0	9,0	13,0	6,0	11,0	Length by agreement in accordance with ISO 888															
40	39,5	40,5			16,5	20,0	14,0	18,0	11,0	16,0											5,75	12,0				
45	44,5	45,5	Length by agreement in accordance with ISO 888		19,0	23,0	16,0	21,0	10,75	17,0											5,5	13,0				
50	49,5	50,5			24,0	28,0	21,0	26,0	15,75	22,0											10,5	18,0				
55	54,4	55,6	Length by agreement in accordance with ISO 888		Length by agreement in accordance with ISO 888		26,0	31,0	20,75	27,0											15,5	23,0	10,25	19,0		
60	59,4	60,6					31,0	36,0	25,75	32,0											20,5	28,0	15,25	24,0		
65	64,4	65,6	Length by agreement in accordance with ISO 888		Length by agreement in accordance with ISO 888		Length by agreement in accordance with ISO 888		30,75	37,0											25,5	33,0	20,25	29,0		
70	69,4	70,6							35,75	42,0											30,5	38,0	25,25	34,0	12,0	22,0
80	79,4	80,6	Length by agreement in accordance with ISO 888		Length by agreement in accordance with ISO 888		Length by agreement in accordance with ISO 888		45,75	52,0											40,5	48,0	35,25	44,0	22,0	32,0
90	89,3	90,7							50,5	58,0											45,25	54,0	32,0	42,0		
100	99,3	100,7	Length by agreement in accordance with ISO 888																							

^a For partially threaded screws, *b* is for reference only.

^b As an option, fully threaded screws can be agreed between the purchaser and the supplier.

^c Fully threaded screws are threaded to the head within 3*P*.

5 Requirements and reference International Standards

The requirements specified in the International Standards listed in [Table 3](#) shall apply. The minimum ultimate tensile loads of full-size fasteners shall meet the minimum values specified in [Table 4](#).

Table 3 — Requirements and reference International Standards

Material		Steel
General requirements	International Standard	ISO 8992
Thread	Tolerance class	6g ^a
	International Standard	ISO 965-1
Mechanical properties	Property class	8.8, 10.9
	International Standard	ISO 898-1 ^b
	Symbol	08.8, 010.9
Tolerances	Product grade	A, except for d_w
	International Standard	ISO 4759-1
Surface condition	As processed (no coating) Electroplated coatings as specified in ISO 4042 Non-electrolytically applied zinc flake coatings as specified in ISO 10683 Additional requirements or other finishes or coatings shall be agreed between the purchaser and the supplier.	
Surface integrity	Limits for surface discontinuities as specified in ISO 6157-1	
Acceptability	Acceptance inspection as specified in ISO 3269	

^a Depending on the type of coating to be applied, another tolerance position of the thread may be specified for the uncoated fastener in accordance with the relevant coating standard.

^b The minimum ultimate tensile loads for these screws with reduced loadability are specified in [Table 4](#).

Table 4 — Minimum ultimate tensile loads — Reduced loadability

Thread <i>d</i>	Minimum ultimate tensile load N	
	Property class	
	8.8	10.9
	Symbol	
	08.8	010.9
M3	3 220	4 190
M4	5 620	7 300
M5	9 120	11 800
M6	12 900	16 800
M8	23 400	30 500
M10	37 100	48 300
M12	54 000	70 200
M16	101 000	130 000

Minimum ultimate tensile loads $F_{m,min}$ (for screws with full loadability) are calculated from the exact figures of $A_{s,nom}$ in accordance with ISO 898-1 and rounded up to three significant digits; minimum ultimate tensile loads for screws with reduced loadability are 80 % of $F_{m,min}$, rounded to three significant digits.

6 Marking and labelling

6.1 Marking on product

Marking on screws shall be as specified in ISO 898-1.

6.2 Labelling on package

Labelling on the package shall be in accordance with ISO 898-1 and shall include at least:

- the reference to this document, i.e. ISO 7380-2;
- the thread size d and nominal length l ;
- the property class symbol;
- the type of surface condition (finish and/or coating);
- the manufacturer's and/or distributor's identification and/or name;
- the manufacturing lot number as specified in ISO 1891-4;
- the quantity of pieces in the package.

7 Designation

The designation requirements as specified in ISO 8991 shall apply for all sizes, with the property class symbol for reduced loadability, as specified in ISO 898-1.

When no specific surface condition (finish and/or coating) is specified in the designation, fasteners are delivered in the as processed condition.

EXAMPLE A hexagon socket button head screw with collar with reduced loadability, thread size M8, of nominal length $l = 40$ mm (therefore partially threaded), property class symbol 010.9, as processed, is designated as follows:

Hexagon socket button head screw ISO 7380-2 - M8 × 40 - 010.9

Bibliography

- [1] ISO 7380-1, *Fasteners — Button head screws with reduced loadability — Part 1: Hexagon socket button head screws*
- [2] ISO 23429, *Gauging of hexagon sockets*

