

Hexagon head bolts
Product grades A and B
(ISO 4014 : 1999)
English version of DIN EN ISO 4014

DIN
EN ISO 4014

ICS 21.060.10

Supersedes DIN EN 24014,
February 1992 edition.

Sechskantschrauben mit Schaft –
Produktklassen A und B (ISO 4014 : 1999)

European Standard EN ISO 4014 : 2000 has the status of a DIN Standard.

A comma is used as the decimal marker.

National foreword

This standard has been published in accordance with a decision taken by CEN/TC 185 to adopt, without alteration, International Standard ISO 4014 as a European Standard.

The responsible German body involved in its preparation was the *Normenausschuss Mechanische Verbindungselemente* (Fasteners Standards Committee), Technical Committee *Schrauben und Muttern mit Außenantrieb*.

The DIN Standards corresponding to the International Standards referred to in clause 2 and in the bibliography of the EN are as follows:

ISO Standard	DIN Standard
ISO 225	DIN EN 20225
ISO 724	DIN ISO 724
ISO 898-1	DIN EN ISO 898-1
ISO 3269	DIN EN ISO 3269
ISO 3506-1	DIN EN ISO 3506-1
ISO 4042	DIN EN ISO 4042
ISO 4753	DIN EN ISO 4753
ISO/DIS 4759-1	DIN EN ISO 4759-1*)
ISO 6157-1	DIN EN 26157-1
ISO 8839	DIN EN 28839
ISO 8992	DIN ISO 8992

*) Currently at draft stage.

Continued overleaf.
EN comprises 14 pages.

Amendments

DIN EN 24014, February 1992 edition, has been superseded by the specifications of EN ISO 4014, which is identical to ISO 4014.

Previous editions

DIN 932-1: 1926-01; DIN 932-2: 1926-01; DIN 600: 1926-10x; DIN 532: 1929-11x; DIN Kr 551: 1935-11, 1936-11; DIN 931-2: 1926-01, 1942-04; DIN 931: 1967-12, 1970-11; DIN 931-1: 1926-01, 1942-04, 1952-12, 1963-03, 1982-07, 1987-09; DIN ISO 4014: 1987-09, 1989-09; DIN EN 24014: 1992-02.

National Annex NA

Standards referred to

(and not included in **Normative references** and **Bibliography**)

DIN EN 20225	Bolts, screws, studs and nuts – Symbols and designations for dimensioning (ISO 225 : 1983)
DIN EN 26157-1	Fasteners – Surface discontinuities – Part 1: Bolts, screws and studs for general requirements (ISO 6157-1 : 1988)
DIN EN 28839	Mechanical properties of fasteners – Bolts, screws, studs and nuts made of non-ferrous metals (ISO 8839 : 1986)
DIN EN ISO 898-1	Mechanical properties of fasteners made of carbon steel and alloy steel – Part 1: Bolts, screws and studs (ISO 898-1 : 1999)
DIN EN ISO 3269	Fasteners – Acceptance inspection (ISO 3269 : 2000)
DIN EN ISO 3506-1	Mechanical properties of corrosion-resistant stainless steel fasteners – Part 1: Bolts, screws and studs (ISO 3506-1 : 1997)
DIN EN ISO 4042	Fasteners – Electroplated coatings (ISO 4042 : 1999)
DIN EN ISO 4753	Fasteners – Ends of parts with external ISO metric screw thread (ISO 4753 : 1999)
DIN ISO 724	ISO general purpose metric screw threads – Basic dimensions (ISO 724 : 1993)



English version

Hexagon head bolts

Product grades A and B
(ISO 4014 : 1999)

Vis à tête hexagonale partiellement
filetées – Grades A et B
(ISO 4014 : 1999)

Sechskantschrauben mit Schaft –
Produktklassen A und B
(ISO 4014 : 1999)

This European Standard was approved by CEN on 2000-10-26.

CEN members are bound to comply with the CEN/CENELEC Internal Regulations which stipulate the conditions for giving this European Standard the status of a national standard without any alteration.

Up-to-date lists and bibliographical references concerning such national standards may be obtained on application to the Central Secretariat or to any CEN member.

The European Standards exist in three official versions (English, French, German). A version in any other language made by translation under the responsibility of a CEN member into its own language and notified to the Central Secretariat has the same status as the official versions.

CEN members are the national standards bodies of Austria, Belgium, the Czech Republic, Denmark, Finland, France, Germany, Greece, Iceland, Ireland, Italy, Luxembourg, the Netherlands, Norway, Portugal, Spain, Sweden, Switzerland, and the United Kingdom.

CEN

European Committee for Standardization
Comité Européen de Normalisation
Europäisches Komitee für Normung

Central Secretariat: rue de Stassart 36, B-1050 Brussels

Foreword

International Standard

ISO 4014 : 1999 Hexagon head bolts – Product grades A and B, which was prepared by ISO/TC 2 'Fasteners' of the International Organization for Standardization, has been adopted by Technical Committee CEN/TC 185 'Threaded and non-threaded mechanical fasteners and accessories', the Secretariat of which is held by DIN, as a European Standard.

This European Standard shall be given the status of a national standard, either by publication of an identical text or by endorsement, and conflicting national standards withdrawn, by May 2001 at the latest.

In accordance with the CEN/CENELEC Internal Regulations, the national standards organizations of the following countries are bound to implement this European Standard:

Austria, Belgium, the Czech Republic, Denmark, Finland, France, Germany, Greece, Iceland, Ireland, Italy, Luxembourg, the Netherlands, Norway, Portugal, Spain, Sweden, Switzerland, and the United Kingdom.

Endorsement notice

The text of the International Standard ISO 4014 : 1999 was approved by CEN as a European Standard without any modification.

Introduction

This International Standard is part of the complete ISO product standard series on external hexagon drive fasteners. The series comprises:

- a) hexagon head bolts (ISO 4014 to ISO 4016 and ISO 8765);
- b) hexagon head screws (ISO 4017, ISO 4018 and ISO 8676);
- c) hexagon nuts (ISO 4032 to ISO 4036, ISO 8673 to ISO 8675);
- d) hexagon bolts with flange (ISO 4162 and ISO 15071);
- e) hexagon nuts with flange (ISO 4161 and ISO 10663);
- f) structural bolts and nuts (ISO 4775, ISO 7411 to ISO 7414 and ISO 7417).

1 Scope

This International Standard specifies the characteristics of hexagon head bolts with threads from M1,6 up to and including M64, of product grade A for threads M1,6 to M24 and nominal lengths up to and including $10 d$ or 150 mm, whichever is shorter and product grade B for threads over M24 or nominal lengths over $10 d$ or 150 mm, whichever is shorter.

If, in special cases, specifications other than those listed in this International Standard are required, they should be selected from existing International Standards, for example ISO 724, ISO 888, ISO 898-1, ISO 965-1, ISO 3506-1, ISO 4753 and ISO 4759-1.

2 Normative references

The following normative documents contain provisions which, through reference in this text, constitute provisions of this International Standard. For dated references, subsequent amendments to, or revisions of, any of these publications do not apply. However, parties to agreements based on this International Standard are encouraged to investigate the possibility of applying the most recent editions of the normative documents indicated below. For undated references, the latest edition of the normative document referred to applies. Members of ISO and IEC maintain registers of currently valid International Standards.

ISO 225:1983, *Fasteners — Bolts, screws, studs and nuts — Symbols and designations of dimensions.*

ISO 724:1993, *ISO general-purpose metric screw threads — Basic dimensions.*

ISO 888:1976, *Bolts, screws and studs — Nominal lengths, and thread lengths for general purpose bolts.*

ISO 898-1:1999, *Mechanical properties of fasteners made of carbon steel and alloy steel — Part 1: Bolts, screws and studs.*

ISO 965-1:1998, *ISO general purpose metric screw threads — Tolerances — Part 1: Principles and basic data.*

ISO 3269:—¹⁾, *Fasteners — Acceptance inspection.*

ISO 3506-1:1997, *Mechanical properties of corrosion-resistant stainless-steel fasteners — Part 1: Bolts, screws and studs.*

ISO 4017:1999, *Hexagon head screws — Product grades A and B.*

ISO 4042:1999, *Fasteners — Electroplated coatings.*

ISO 4753:—²⁾, *Fasteners — Ends of parts with external metric ISO thread.*

¹⁾ To be published. (Revision of ISO 3269:1988)

²⁾ To be published. (Revision of ISO 4753:1983)

ISO 4759-1:—³⁾, *Tolerances for fasteners — Part 1: Bolts, screws, studs and nuts — Product grades A, B and C.*

ISO 6157-1:1988, *Fasteners — Surface discontinuities — Part 1: Bolts, screws and studs for general requirements.*

ISO 8839:1986, *Mechanical properties of fasteners — Bolts, screws, studs and nuts made of non-ferrous metals.*

ISO 8992:1986, *Fasteners — General requirements for bolts, screws, studs and nuts.*

ISO 10683:—⁴⁾, *Fasteners — Non-electrolytically applied zinc flake coatings.*

3 Dimensions

See Figure 1 and Tables 1 and 2

Symbols and description of dimensions are defined in ISO 225.

FINESZ 泛微

³⁾ To be published. (Revision of ISO 4759-1:1978)

⁴⁾ To be published.

Dimensions in millimetres

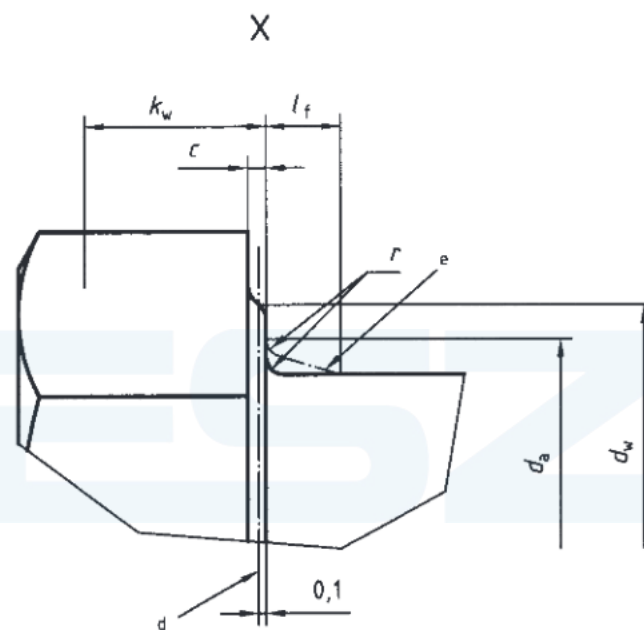
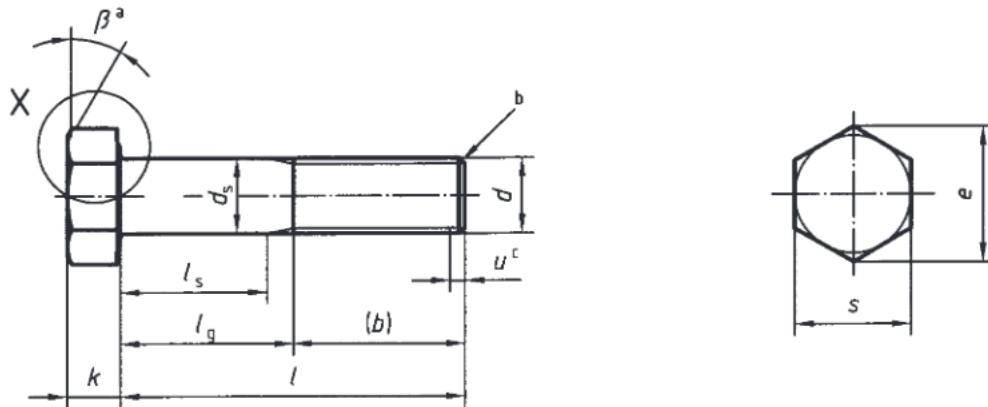

- a $\beta = 15^\circ$ to 30°
- b Point shall be chamfered or for threads $\leq M4$ may be as-rolled (sheared end) (see ISO 4753)
- c Incomplete thread $u \leq 2P$
- d Referee datum for d_w
- e Maximum underhead fillet

Figure 1

Table 1 — Preferred threads

Thread (<i>d</i>)	M1,6	M2	M2,5	M3	M4	M5	M6	M8	M10
<i>p</i> _a	0,35	0,4	0,45	0,5	0,7	0,8	1	1,25	1,5
<i>b</i> ref.	9	10	11	12	14	16	18	22	26
<i>c</i>	15	16	17	18	20	22	24	28	32
<i>d</i>	28	29	30	31	33	35	37	41	45
<i>c</i>	max. 0,25	0,25	0,25	0,40	0,40	0,50	0,50	0,60	0,60
	min. 0,10	0,10	0,10	0,15	0,15	0,15	0,15	0,15	0,15
<i>d</i> _a	max. 2	2,6	3,1	3,6	4,7	5,7	6,8	9,2	11,2
<i>d</i> _s	nom. = max. 1,60	2,00	2,50	3,00	4,00	5,00	6,00	8,00	10,00
	A min. 1,46	1,86	2,36	2,86	3,82	4,82	5,82	7,78	9,78
	B 1,35	1,75	2,25	2,75	3,70	4,70	5,70	7,64	9,64
<i>d</i> _w	Product grade A min. 2,27	3,07	4,07	4,57	5,88	6,88	8,88	11,63	14,63
	B 2,3	2,95	3,95	4,45	5,74	6,74	8,74	11,47	14,47
<i>e</i>	Product grade A min. 3,41	4,32	5,45	6,01	7,66	8,79	11,05	14,38	17,77
	B 3,28	4,18	5,31	5,88	7,50	8,63	10,89	14,20	17,59
<i>l</i> _f	max. 0,6	0,8	1	1	1,2	1,2	1,4	2	2
	norm. 1,1	1,4	1,7	2	2,8	3,5	4	5,3	6,4
<i>k</i>	Product grade A max. 1,225	1,525	1,825	2,125	2,925	3,65	4,15	5,45	6,58
	min. 0,975	1,275	1,575	1,875	2,675	3,35	3,85	5,15	6,22
	Product grade B max. 1,3	1,6	1,9	2,2	3,0	3,26	4,24	5,54	6,69
	min. 0,9	1,2	1,5	1,8	2,6	2,35	3,76	5,06	6,11
<i>k</i> _w ⁶	Product grade A min. 0,68	0,89	1,10	1,31	1,87	2,35	2,70	3,61	4,35
	B 0,63	0,84	1,05	1,26	1,82	2,28	2,63	3,54	4,28
<i>r</i>	min. 0,1	0,1	0,1	0,1	0,2	0,2	0,25	0,4	0,4
	nom. = max. 3,20	4,00	5,00	5,50	7,00	8,00	10,00	13,00	16,00
<i>s</i>	Product grade A min. 3,02	3,82	4,82	5,32	6,78	7,78	9,78	12,73	15,73
	B 2,90	3,70	4,70	5,20	6,64	7,64	9,64	12,57	15,57

Dimensions in millimetres



nom.	Product grade		l_s and l'_g																			
	A		B		l		l_s		l'_g		l_s		l'_g		l_s		l'_g		l_s		l'_g	
	min.	max.	min.	max.	min.	max.	min.	max.	min.	max.	min.	max.	min.	max.	min.	max.	min.	max.	min.	max.	min.	max.
12	11,65	12,35	—	—	1,2	3	4	6	2,75	5	7,5	11	5	9	11,75	18	—	—	—	—	—	—
16	15,65	16,35	—	—	5,2	7	8	10	6,75	9	12,5	16	10	14	17,5	22	22	27	11,75	23	11,5	19
20	19,58	20,42	18,95	21,05	—	—	—	—	—	—	—	—	—	—	—	—	—	—	—	—	—	—
25	24,58	25,42	23,95	26,05	—	—	—	—	—	—	—	—	—	—	—	—	—	—	—	—	—	—
30	29,58	30,42	28,95	31,05	—	—	—	—	—	—	—	—	—	—	—	—	—	—	—	—	—	—
35	34,5	35,5	33,75	36,25	—	—	—	—	—	—	—	—	—	—	—	—	—	—	—	—	—	—
40	39,5	40,5	38,75	41,25	—	—	—	—	—	—	—	—	—	—	—	—	—	—	—	—	—	—
45	44,5	45,5	43,75	46,25	—	—	—	—	—	—	—	—	—	—	—	—	—	—	—	—	—	—
50	49,5	50,5	48,75	51,25	—	—	—	—	—	—	—	—	—	—	—	—	—	—	—	—	—	—
55	54,4	55,6	53,5	56,5	—	—	—	—	—	—	—	—	—	—	—	—	—	—	—	—	—	—
60	59,4	60,6	58,5	61,5	—	—	—	—	—	—	—	—	—	—	—	—	—	—	—	—	—	—
65	64,4	65,6	63,5	66,5	—	—	—	—	—	—	—	—	—	—	—	—	—	—	—	—	—	—
70	69,4	70,6	68,5	71,5	—	—	—	—	—	—	—	—	—	—	—	—	—	—	—	—	—	—
80	79,4	80,6	78,5	81,5	—	—	—	—	—	—	—	—	—	—	—	—	—	—	—	—	—	—
90	89,3	90,7	88,25	91,75	—	—	—	—	—	—	—	—	—	—	—	—	—	—	—	—	—	—
100	99,3	100,7	98,25	101,75	—	—	—	—	—	—	—	—	—	—	—	—	—	—	—	—	—	—
110	109,3	110,7	108,25	111,75	—	—	—	—	—	—	—	—	—	—	—	—	—	—	—	—	—	—
120	119,3	120,7	118,25	121,75	—	—	—	—	—	—	—	—	—	—	—	—	—	—	—	—	—	—

For sizes above the solid, boldface stepped line ISO 4017 is recommended

Table 1 (continued)

Thread (d)	Dimensions in millimetres												
	M12	M16	M20	M24	M30	M36	M42	M48	M56	M64			
p^a	1,75	2	2,5	3	3,5	4	4,5	5	5,5	6			
b	30	38	46	54	66	—	—	—	—	—			
c	36	44	52	60	72	84	96	108	—	—			
d	49	57	65	73	85	97	109	121	137	153			
c	max. 0,60	0,8	0,8	0,8	0,8	0,8	1,0	1,0	1,0	1,0			
	min. 0,15	0,2	0,2	0,2	0,2	0,2	0,3	0,3	0,3	0,3			
d_a	max. 13,7	17,7	22,4	26,4	33,4	39,4	45,6	52,6	63	71			
d_s	nom. = max. 12,00	16,00	20,00	24,00	30,00	36,00	42,00	48,00	56,00	64,00			
Product grade	A min. 11,73	15,73	19,67	23,67	—	—	—	—	—	—			
	B 11,57	15,57	19,48	23,48	29,48	35,38	41,38	47,38	55,26	63,26			
d_w	A min. 16,63	22,49	28,19	33,61	—	—	—	—	—	—			
	B 16,47	22	27,7	33,25	42,75	51,11	59,95	69,45	78,66	88,16			
e	A min. 20,03	26,75	33,53	39,98	—	—	—	—	—	—			
	B 19,85	26,17	32,95	39,55	50,85	60,79	71,3	82,6	93,56	104,86			
l_f	max. 3	3	4	4	6	6	8	10	12	13			
	nom. 7,5	10	12,5	15	18,7	22,5	26	30	35	40			
Product grade	A max. 7,68	10,18	12,715	15,215	—	—	—	—	—	—			
	min. 7,32	9,82	12,285	14,785	—	—	—	—	—	—			
k	Product grade	A max. 7,79	10,29	12,85	15,35	19,12	22,92	26,42	30,42	35,5	40,5		
	B max. 7,21	9,71	12,15	14,65	18,28	22,08	25,58	29,58	34,5	39,5			
k_w^e	A min. 5,12	6,87	8,6	10,35	—	—	—	—	—	—			
	B 5,05	6,8	8,51	10,26	12,8	15,46	17,91	20,71	24,15	27,65			
r	min. 0,6	0,6	0,8	0,8	1	1	1,2	1,6	2	2			
	nom. = max. 18,00	24,00	30,00	36,00	46	55,0	65,0	75,0	85,0	95,0			
s	Product grade	A min. 17,73	23,67	35,38	—	—	—	—	—	—			
	B 17,57	23,16	29,16	35,00	45	53,8	63,1	73,1	82,8	92,8			

nom.	Product grade A		Product grade B		<i>l_s and l_g</i>																	
	<i>l</i>		<i>l_s</i>		<i>l_g</i>		<i>l_s</i>		<i>l_g</i>		<i>l_s</i>		<i>l_g</i>		<i>l_s</i>		<i>l_g</i>		<i>l_s</i>		<i>l_g</i>	
	min.	max.	min.	max.	min.	max.	min.	max.	min.	max.	min.	max.	min.	max.	min.	max.	min.	max.	min.	max.	min.	max.
50	49,5	50,5	—	—	11,25	20	—	—	—	—	—	—	—	—	—	—	—	—	—	—	—	—
55	54,4	55,6	53,5	56,5	16,25	25	—	—	—	—	—	—	—	—	—	—	—	—	—	—	—	—
60	59,4	60,6	58,5	61,5	21,25	30	—	—	—	—	—	—	—	—	—	—	—	—	—	—	—	—
65	64,4	65,6	63,5	66,5	26,25	35	17	27	—	—	—	—	—	—	—	—	—	—	—	—	—	—
70	69,4	70,6	68,5	71,5	31,25	40	22	32	—	—	—	—	—	—	—	—	—	—	—	—	—	—
80	79,4	80,6	78,5	81,5	41,25	50	32	42	21,5	34	—	—	—	—	—	—	—	—	—	—	—	—
90	89,3	90,7	88,25	91,75	51,25	60	42	52	31,5	44	21	36	—	—	—	—	—	—	—	—	—	—
100	99,3	100,7	98,25	101,75	61,25	70	52	62	41,5	54	31	46	—	—	—	—	—	—	—	—	—	—
110	109,3	110,7	108,25	111,75	71,25	80	62	72	51,5	64	41	56	26,5	44	—	—	—	—	—	—	—	—
120	119,3	120,7	118,25	121,75	81,25	90	72	82	61,5	74	51	66	36,5	54	—	—	—	—	—	—	—	—
130	129,2	130,8	128	132	—	—	76	86	65,5	78	55	70	40,5	58	—	—	—	—	—	—	—	—
140	139,2	140,8	138	142	—	—	86	96	75,5	88	65	80	50,5	68	36	56	—	—	—	—	—	—
150	149,2	150,8	148	152	—	—	96	106	85,5	98	75	90	60,5	78	46	66	—	—	—	—	—	—
160	—	—	158	162	—	—	106	116	95,5	108	85	100	70,5	88	56	76	41,5	64	—	—	—	—
180	—	—	178	182	—	—	—	—	115,5	128	105	120	90,5	108	76	96	61,5	84	47	72	—	—
200	—	—	197,7	202,3	—	—	—	—	135,5	148	125	140	110,5	128	96	116	81,5	104	67	92	—	—
220	—	—	217,7	222,3	—	—	—	—	—	—	132	147	117,5	135	103	123	88,5	111	74	99	55,5	83
240	—	—	237,7	242,3	—	—	—	—	—	—	152	167	137,5	155	123	143	108,5	131	94	119	75,5	103
260	—	—	257,4	262,6	—	—	—	—	—	—	—	—	157,5	175	143	163	128,5	151	114	139	95,5	123
280	—	—	277,4	282,6	—	—	—	—	—	—	—	—	177,5	195	163	183	148,5	171	134	159	115,5	143
300	—	—	297,4	302,6	—	—	—	—	—	—	—	—	197,5	215	183	203	168,5	191	154	179	135,5	163
320	—	—	317,15	322,85	—	—	—	—	—	—	—	—	—	—	203	223	188,5	211	174	199	155,5	183
340	—	—	337,15	342,85	—	—	—	—	—	—	—	—	—	—	223	243	208,5	231	194	219	175,5	203
360	—	—	357,15	362,85	—	—	—	—	—	—	—	—	—	—	243	263	228,5	251	214	239	195,5	223
380	—	—	377,15	382,85	—	—	—	—	—	—	—	—	—	—	—	—	248,5	271	234	259	215,5	243
400	—	—	397,15	402,85	—	—	—	—	—	—	—	—	—	—	—	—	268,5	291	254	279	235,5	263
420	—	—	416,85	423,15	—	—	—	—	—	—	—	—	—	—	—	—	—	—	—	—	—	—
440	—	—	436,85	443,15	—	—	—	—	—	—	—	—	—	—	—	—	—	—	—	—	—	—
460	—	—	456,85	463,15	—	—	—	—	—	—	—	—	—	—	—	—	—	—	—	—	—	—
480	—	—	476,85	483,15	—	—	—	—	—	—	—	—	—	—	—	—	—	—	—	—	—	—
500	—	—	496,85	503,15	—	—	—	—	—	—	—	—	—	—	—	—	—	—	—	—	—	—

NOTE Popular lengths are defined in terms of *l_s* and *l_g*:
 — for product grade A, above the dashed, stepped line;
 — for product grade B, below this stepped line.

- a *P* is the pitch of the thread.
- b For lengths $l_{nom} \leq 125$ mm.
- c For lengths $125 \text{ mm} < l_{nom} \leq 200$ mm.
- d For lengths $l_{nom} > 200$ mm.

- e $k_w, \min = 0,7 k_{\min}$
- f $l_{g, \max} = l_{nom} - b$
- g $l_{s, \min} = l_{g, \max} - 5P$
- g l_g is the minimum grip length.

Table 2 — Non-preferred threads

Dimensions in millimetres

Thread (<i>d</i>)			M3,5	M14	M18	M22	M27							
p^a			0,6	2	2,5	2,5	3							
<i>b</i> ref.	b		13	34	42	50	60							
	c		19	40	48	56	66							
	d		32	53	61	69	79							
<i>c</i>	max.		0,40	0,60	0,8	0,8	0,8							
	min.		0,15	0,15	0,2	0,2	0,2							
d_a	max.		4,1	15,7	20,2	24,4	30,4							
d_s	nom. = max.		3,50	14,00	18,00	22,00	27,00							
	Product grade	A min.	3,32	13,73	17,73	21,67	—							
		B	3,20	13,57	17,57	21,48	26,48							
d_w	Product grade	A min.	5,07	19,64	25,34	31,71	—							
	B		4,95	19,15	24,85	31,35	38							
<i>e</i>	Product grade	A min.	6,58	23,36	30,14	37,72	—							
	B		6,44	22,78	29,56	37,29	45,2							
l_f	max.		1	3	3	4	6							
	nom.		2,4	8,8	11,5	14	17							
<i>k</i>	Product grade	A max.	2,525	8,98	11,715	14,215	—							
		min.	2,275	8,62	11,285	13,785	—							
	Product grade	B max.	2,6	9,09	11,85	14,35	17,35							
		min.	2,2	8,51	11,15	13,65	16,65							
k_w^e	Product grade	A min.	1,59	6,03	7,9	9,65	—							
	B		1,54	5,96	7,81	9,56	11,66							
<i>r</i>	min.		0,1	0,6	0,6	0,8	1							
<i>s</i>	nom. = max.		6,00	21,00	27,00	34,00	41							
	Product grade	A min.	5,82	20,67	26,67	33,38	—							
		B	5,70	20,16	26,16	33,00	40							
Product grade														
A B			l_s and l_g^{fg}											
<i>l</i>					l_s	l_g	l_s	l_g	l_s	l_g	l_s	l_g	l_s	l_g
nom.	min.	max.	min.	max.	min.	max.	min.	max.	min.	max.	min.	max.	min.	max.
20	19,58	20,42	—	—	4	7								
25	24,58	25,42	—	—	9	12								
30	29,58	30,42	—	—	14	17								
35	34,5	35,5	—	—	19	22								
40	39,5	40,5	38,75	41,25			For sizes above the dashed, boldface stepped line ISO 4017 is recommended.							
45	44,5	45,5	43,75	46,25										
50	49,5	50,5	48,75	51,25										
55	54,4	55,6	53,5	56,5										
60	59,4	60,6	58,5	61,5			16	26						
65	64,4	65,6	63,5	66,5			21	31						
70	69,4	70,6	68,5	71,5			26	36	15,5	28				
80	79,4	80,6	78,5	81,5			36	46	25,5	38				
90	89,3	90,7	88,25	91,75			46	56	35,5	48	27,5	40		
100	99,3	100,7	98,25	101,75			56	66	45,5	58	37,5	50	25	40
110	109,3	110,7	108,25	111,75			66	76	55,5	68	47,5	60	35	50
120	119,3	120,7	118,25	121,75			76	86	65,5	78	57,5	70	45	60
130	129,2	130,8	128	132			80	90	69,5	82	61,5	74	49	64
140	139,2	140,8	138	142			90	100	79,5	92	71,5	84	59	74
150	149,2	150,8	148	152					89,5	102	81,5	94	69	84
160	—	—	158	162					99,5	112	91,5	104	79	94
180	—	—	178	182					119,5	132	111,5	124	99	114
200	—	—	197,7	202,3							131,5	144	119	134
220	—	—	217,7	222,3							138,5	151	126	141
240	—	—	237,7	242,3									146	161
260	—	—	257,4	262,6									166	181

Thread (d)			M33	M39	M45	M52	M60	
p^a			3,5	4	4,5	5	5,5	
b ref	b		—	—	—	—	—	
	c		78	90	102	116	—	
	d		91	103	115	129	145	
c	max.		0,8	1,0	1,0	1,0	1,0	
	min.		0,2	0,3	0,3	0,3	0,3	
d_a	max.		36,4	42,4	48,6	56,6	67	
d_s	nom. = max.		33,00	39,00	45,00	52,00	60,00	
	Product grade	A min.	—	—	—	—	—	
		B		32,38	38,38	44,38	51,26	59,26
d_w	Product grade	A min.	—	—	—	—	—	
		B		46,55	55,86	64,7	74,2	83,41
e	Product grade	A min.	—	—	—	—	—	
		B		55,37	66,44	76,95	88,25	99,21
l_f	max.		6	6	8	10	12	
	nom.		21	25	28	33	38	
k	Product grade	A max.	—	—	—	—	—	
		min.	—	—	—	—	—	
	Product grade	B max.		21,42	25,42	28,42	33,5	38,5
		min.		20,58	24,58	27,58	32,5	37,5
k_w^e	Product grade	A min.	—	—	—	—	—	
		B		14,41	17,21	19,31	22,75	26,25
r	min.		1	1	1,2	1,6	2	
s	nom. = max.		50	60,0	70,0	80,0	90,0	
	Product grade	A min.	—	—	—	—	—	
		B		49	58,8	68,1	78,1	87,8

Product grade					l_s and l_g^{fg}																
A					B					l_s		l_g		l_s		l_g		l_s		l_g	
nom.	min.	max.	min.	max.	min.	max.	min.	max.	min.	max.	min.	max.	min.	max.	min.	max.	min.	max.	min.	max.	
130	129,2	130,8	128	132	34,5	52	For sizes above the solid, boldface stepped line ISO 4017 is recommended														
140	139,2	140,8	138	142	44,5	62															
150	149,2	150,8	148	152	54,5	72	40	60													
160	—	—	158	162	64,5	82	50	70													
180	—	—	178	182	84,5	102	70	90	55,5	78											
200	—	—	197,7	202,3	104,5	122	90	110	75,5	98	59	84									
220	—	—	217,7	222,3	111,5	129	97	117	82,5	105	66	91									
240	—	—	237,7	242,3	131,5	149	117	137	102,5	125	86	111	67,5	95							
260	—	—	257,4	262,6	151,5	169	137	157	122,5	145	106	131	87,5	115							
280	—	—	277,4	282,6	171,5	189	157	177	142,5	165	126	151	107,5	135							
300	—	—	297,4	302,6	191,5	209	177	197	162,5	185	146	171	127,5	155							
320	—	—	317,15	322,85	211,5	229	197	217	182,5	205	166	191	147,5	175							
340	—	—	337,15	342,85			217	237	202,5	225	186	211	167,5	195							
360	—	—	357,15	362,85			237	257	222,5	245	206	231	187,5	215							
380	—	—	377,15	382,85			257	277	242,5	265	226	251	207,5	235							
400	—	—	397,15	402,85					262,5	285	246	271	227,5	255							
420	—	—	416,85	423,15					282,5	305	266	291	247,5	275							
440	—	—	436,85	443,15					302,5	325	286	311	267,5	295							
460	—	—	456,85	463,15							306	331	287,5	315							
480	—	—	476,85	483,15							326	351	307,5	335							
500	—	—	496,85	503,15									327,5	355							

NOTE Popular lengths are defined in terms of l_s and l_g :
 — for product grade A, above the dashed, stepped line;
 — for product grade B, below this stepped line.

^a p is the pitch of the thread.

^b For lengths $l_{nom} \leq 125$ mm.

^c For lengths $125 \text{ mm} < l_{nom} \leq 200$ mm.

^d For lengths $l_{nom} > 200$ mm.

$$^e k_{w, \min} = 0,7 k_{\min}$$

$$^f l_{g, \max} = l_{nom} - b$$

$$l_{s, \min} = l_{g, \max} - 5P$$

^g l_g is the minimum grip length.

4 Specifications and reference standards

See Table 3.

Table 3 — Specifications and reference standards

Material		Steel	Stainless steel	Non-ferrous metal
General requirements	International Standard	ISO 8992		
Thread	Tolerance	6g		
	International Standards	ISO 724, ISO 965-1		
Mechanical properties	Property class ^a	$d < 3$ mm: as agreed $3 \text{ mm} \leq d \leq 39$ mm: 5.6, 8.8, 9.8, 10.9 $d > 39$ mm: as agreed	$d \leq 24$ mm: A2-70, A4-70 $24 \text{ mm} < d \leq 39$ mm: A2-50, A4-50 $d > 39$ mm: as agreed	Materials specified in ISO 8839
	International Standards	$3 \text{ mm} \leq d \leq 39$ mm: ISO 898-1 $d < 3$ mm and $d > 39$ mm: as agreed	$d \leq 39$ mm: ISO 3506-1 $d > 39$ mm: as agreed	
Tolerances	Product grade	For $d \leq 24$ mm and $l \leq 10 d$ or 150 mm ^b : A For $d > 24$ mm or $l > 10 d$ or 150 mm ^b : B		
	International Standard	ISO 4759-1		
Finish and/or coating		As processed Requirements for electroplating are covered in ISO 4042 Requirements for non-electrolytically applied zinc flake coatings are covered in ISO 10683 If different electroplating requirements are desired or if requirements are needed for other finishes, they should be agreed between customer and supplier. Limits for surface discontinuities are covered in ISO 6157-1	Plain	Plain Requirements for electroplating are covered in ISO 4042
Acceptability		For acceptance procedure, see ISO 3269.		

^a For other property classes see ISO 898-1 for steel and ISO 3506-1 for stainless steel respectively.
^b Whichever is shorter.

5 Designation

EXAMPLE

A hexagon head bolt with thread M12, nominal length $l = 80$ mm and property class 8.8 is designated as follows:

Hexagon head bolt ISO 4014 - M12 × 80 - 8.8

Bibliography

- [1] ISO 4015:1979, *Hexagon head bolts — Product grade B — Reduced shank (shank diameter approximately equal to pitch diameter)*.
- [2] ISO 4016:1999, *Hexagon head bolts — Product grade C*.
- [3] ISO 4017:1999, *Hexagon head screws — Product grades A and B*.
- [4] ISO 4018:1999, *Hexagon head screws — Product grade C*.
- [5] ISO 4032:1999, *Hexagon nuts, style 1 — Product grades A and B*.
- [6] ISO 4033:1999, *Hexagon nuts, style 2 — Product grades A and B*.
- [7] ISO 4034:1999, *Hexagon nuts — Product grade C*.
- [8] ISO 4035:1999, *Hexagon thin nuts (chamfered) — Product grades A and B*.
- [9] ISO 4036:1999, *Hexagon thin nuts (unchamfered) — Product grade B*.
- [10] ISO 4161:1999, *Hexagon nuts with flange — Coarse thread*.
- [11] ISO 4162:—⁵⁾, *Hexagon bolts with flange — Small series — Product grade combination A/B*.
- [12] ISO 4775:1984, *Hexagon nuts for high-strength structural bolting with large width across flats — Product grade B — Property classes 8 and 10*.
- [13] ISO 7411:1984, *Hexagon bolts for high-strength structural bolting with large width across flats (thread lengths according to ISO 888) — Product grade C — Property classes 8.8 and 10.9*.
- [14] ISO 7412:1984, *Hexagon bolts for high-strength structural bolting with large width across flats (short thread length) — Product grade C — Property classes 8.8 and 10.9*.
- [15] ISO 7413:1984, *Hexagon nuts for structural bolting, style 1, hot-dip galvanize (oversize tapped) — Product grades A and B — Property classes 5, 6 and 8*.
- [16] ISO 7414:1984, *Hexagon nuts for structural bolting with large width across flats, style 1 — Product grade B — Property class 10*.
- [17] ISO 7417:1984, *Hexagon nuts for structural bolting, style 2, hot-dip galvanize (oversize tapped) — Product grade A — Property class 9*.
- [18] ISO 8673:1999, *Hexagon nuts, style 1, with metric fine pitch thread — Product grades A and B*.
- [19] ISO 8674:1999, *Hexagon nuts, style 2, with metric fine pitch thread — Product grades A and B*.
- [20] ISO 8675:1999, *Hexagon thin nuts (chamfered) with metric fine pitch thread — Product grades A and B*.
- [21] ISO 8676:1999, *Hexagon head screws with metric fine pitch thread — Product grades A and B*.

⁵⁾ To be published. (Revision of ISO 4162:1990)

[22] ISO 8765:1999, *Hexagon head bolts with metric fine pitch thread — Product grades A and B.*

[23] ISO 10663:1999, *Hexagon nuts with flange — Fine pitch thread.*

[24] ISO 15071:1999, *Hexagon bolts with flange — Small series — Product grade A.*

FINESZ 泛微