**Hexalobular internal driving feature
for bolts and screws**

Empreinte à six lobes internes pour vis

FINESZ 泛微



Reference number
ISO 10664:2005(E)

© ISO 2005

PDF disclaimer

This PDF file may contain embedded typefaces. In accordance with Adobe's licensing policy, this file may be printed or viewed but shall not be edited unless the typefaces which are embedded are licensed to and installed on the computer performing the editing. In downloading this file, parties accept therein the responsibility of not infringing Adobe's licensing policy. The ISO Central Secretariat accepts no liability in this area.

Adobe is a trademark of Adobe Systems Incorporated.

Details of the software products used to create this PDF file can be found in the General Info relative to the file; the PDF-creation parameters were optimized for printing. Every care has been taken to ensure that the file is suitable for use by ISO member bodies. In the unlikely event that a problem relating to it is found, please inform the Central Secretariat at the address given below.

FINESZ 泛微

© ISO 2005

All rights reserved. Unless otherwise specified, no part of this publication may be reproduced or utilized in any form or by any means, electronic or mechanical, including photocopying and microfilm, without permission in writing from either ISO at the address below or ISO's member body in the country of the requester.

ISO copyright office
Case postale 56 • CH-1211 Geneva 20
Tel. + 41 22 749 01 11
Fax + 41 22 749 09 47
E-mail copyright@iso.org
Web www.iso.org

Published in Switzerland

Foreword

ISO (the International Organization for Standardization) is a worldwide federation of national standards bodies (ISO member bodies). The work of preparing International Standards is normally carried out through ISO technical committees. Each member body interested in a subject for which a technical committee has been established has the right to be represented on that committee. International organizations, governmental and non-governmental, in liaison with ISO, also take part in the work. ISO collaborates closely with the International Electrotechnical Commission (IEC) on all matters of electrotechnical standardization.

International Standards are drafted in accordance with the rules given in the ISO/IEC Directives, Part 2.

The main task of technical committees is to prepare International Standards. Draft International Standards adopted by the technical committees are circulated to the member bodies for voting. Publication as an International Standard requires approval by at least 75 % of the member bodies casting a vote.

Attention is drawn to the possibility that some of the elements of this document may be the subject of patent rights. ISO shall not be held responsible for identifying any or all such patent rights.

ISO 10664 was prepared by Technical Committee ISO/TC 2, *Fasteners*.

This second edition cancels and replaces the first edition (ISO 10664:1999), which has been technically revised.

FINESZ 泛微

www.fine.com.cn

Hexalobular internal driving feature for bolts and screws

1 Scope

This International Standard specifies the shape and basic dimensions of the hexalobular internal driving feature for bolts and screws, including the gauging method.

The curvature of the contour of the hexalobular internal driving feature is defined by the gauges specified in Tables 3, 4 and 5. Additional information which can be used when drawing the contour is given in Annex A.

The intent of this International Standard is to provide the details necessary for inspection of the hexalobular driving feature. It is not suitable for, nor intended to be used as, a manufacturing standard.

2 Basic dimensions

See Figure 1 and Table 1.

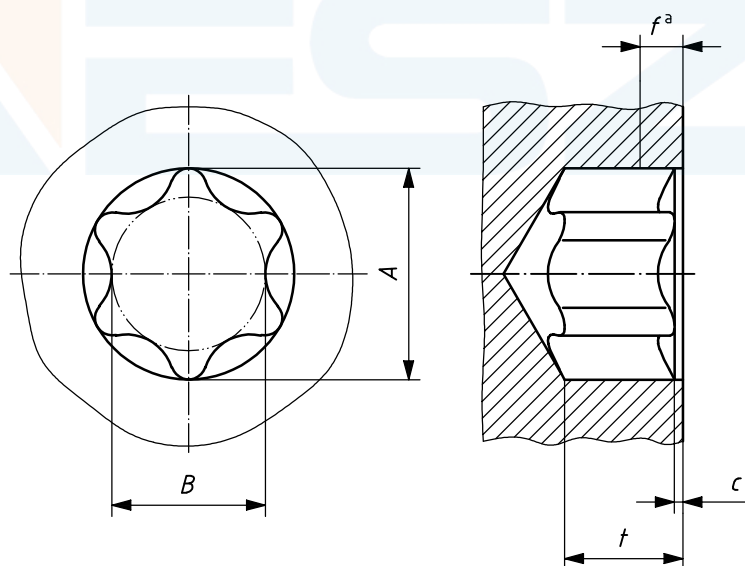

Counterbore: $c \leq 0,13$ mm up to socket No. 15

$c \leq 0,25$ mm over socket No. 15

Penetration depth t : see relevant product standard.

NOTE The contour of the bottom of the socket beyond the gauge is at the option of the manufacturer.

^a See Table 2.

Figure 1 — Basic dimensions

Table 1 — Basic dimensions

Dimensions in millimetres

Hexalobular socket No.	Nominal dimensions ^a	
	<i>A</i>	<i>B</i>
6	1,75	1,27
8	2,4	1,75
10	2,8	2,05
15	3,35	2,4
20	3,95	2,85
25	4,5	3,25
30	5,6	4,05
40	6,75	4,85
45	7,93	5,64
50	8,95	6,45
55	11,35	8,05
60	13,45	9,6
70	15,7	11,2
80	17,75	12,8
90	20,2	14,4
100	22,4	16

^a The curvature of the contour of the hexalobular internal driving feature is defined by the gauges specified in Tables 3, 4 and 5.

3 Gauging

3.1 Principle

The hexalobular internal driving feature shall allow the GO gauge (see 3.2) to enter freely to the penetration depth t , as specified in the relevant product standards.

The NO GO gauges (see 3.3.1 and 3.3.2) shall not enter the hexalobular internal driving feature to a depth greater than the fallaway allowance specified in Table 2.

Table 2 — Fallaway allowance

Dimensions in millimetres

Socket No.	6	8	10	15	20	25	30	40	45	50	55	60	70	80	90	100
Fallaway allowance, f	0,35	0,48	0,56	0,67	0,79	0,90	1,12	1,18	1,39	1,56	1,98	2,35	2,75	3,11	3,53	3,92

All gauging is performed with reference to the top surface of the head. In the case of oval or round top heads, measurements are taken from the actual intersection of the top surface of the head and the hexalobular internal driving feature counterbore.

When using a dial penetration gauge, this should be adjusted to zero while the gauge is pressed against a flat surface, thereby compressing the plunger to make it flush with the gauge reference surface, see Figure 2.

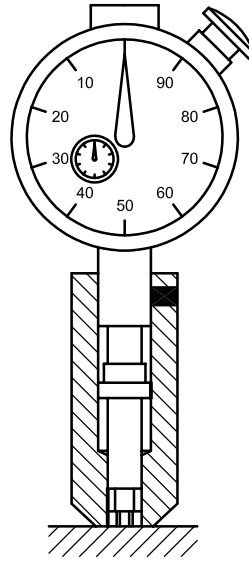
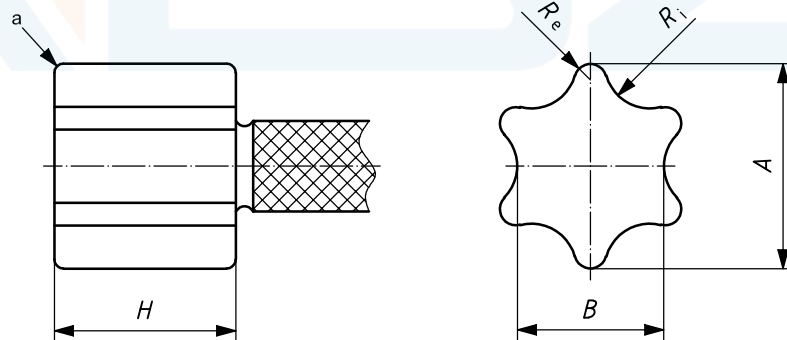

Figure 2 — Dial gauge (zero position)

3.2 GO gauge

The GO gauge dimensions (see Figure 3) shall be within the limits specified in Table 3.



^a Radius max. 0,076 mm at juncture of side and face to gauge sizes \geq No. 10 and max. 0,025 4 mm for gauge sizes $<$ No. 10.

Figure 3 — Dimensions of GO gauge

Table 3 — Limiting sizes of GO gauge dimensions

Dimensions in millimetres

Socket No.	A		B		R _i		R _e		H	
	min.	max.	min.	max.	min.	max.	min.	max.	min.	max.
6	1,695	1,709	1,210	1,224	0,371	0,396	0,130	0,134	1,33	1,82
8	2,335	2,349	1,672	1,686	0,498	0,523	0,188	0,193	2,54	3,05
10	2,761	2,776	1,979	1,993	0,585	0,609	0,227	0,231	3,05	3,56
15	3,295	3,309	2,353	2,367	0,704	0,728	0,265	0,269	3,30	3,81
20	3,879	3,893	2,764	2,778	0,846	0,871	0,303	0,307	3,56	4,07
25	4,451	4,465	3,170	3,185	0,907	0,932	0,371	0,378	3,94	4,45
30	5,543	5,557	3,958	3,972	1,182	1,206	0,448	0,454	4,44	4,95
40	6,673	6,687	4,766	4,780	1,415	1,440	0,544	0,548	5,08	5,59
45	7,841	7,856	5,555	5,570	1,784	1,808	0,572	0,576	5,71	6,22
50	8,857	8,872	6,366	6,380	1,804	1,828	0,773	0,777	5,97	6,48
55	11,245	11,259	7,930	7,945	2,657	2,682	0,765	0,769	6,22	6,73
60	13,302	13,317	9,490	9,504	2,871	2,895	1,065	1,069	7,68	8,17
70	15,588	15,603	11,085	11,099	3,465	3,489	1,192	1,196	8,46	8,96
80	17,619	17,635	12,646	12,661	3,625	3,629	1,524	1,529	9,4	9,9
90	20,021	20,035	14,232	14,246	4,456	4,480	1,527	1,534	10,06	10,56
100	22,231	22,245	15,820	15,834	4,913	4,937	1,718	1,724	10,85	11,35

3.3 NO GO gauges

3.3.1 Gauging the fallaway of dimensions A and R_e

The NO GO gauge for dimensions A and R_e (see Figure 4) shall have dimensions within the limits specified in Table 4.

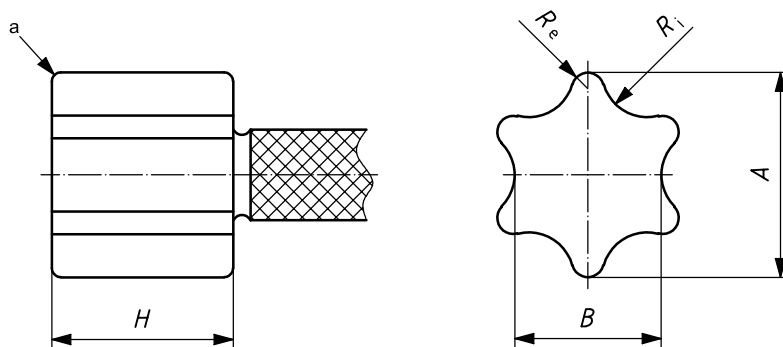

^a Radius max. 0,076 mm at juncture of side and face for gauge sizes ≥ No. 10 and max. 0,025 4 mm for gauge sizes < No. 10

Figure 4 — NO GO gauge for dimensions A and R_e

Table 4 — Limiting sizes of dimensions of NO GO gauge for dimensions A and R_e

Dimensions in millimetres

Socket No.	A		B	R_i		R_e		H
	min.	max.	max.	min.	max.	min.	max.	$\pm 0,25$
6	1,778	1,785	1,181	0,231	0,241	0,173	0,180	1,57
8	2,419	2,425	1,664	0,36	0,37	0,231	0,238	2,79
10	2,845	2,852	1,956	0,431	0,441	0,269	0,276	3,3
15	3,379	3,385	1,956	0,398	0,408	0,307	0,315	3,56
20	3,963	3,970	2,616	0,602	0,614	0,345	0,353	3,81
25	4,560	4,566	2,868	0,637	0,647	0,429	0,436	4,19
30	5,652	5,659	3,886	0,939	0,949	0,505	0,513	4,7
40	6,807	6,814	4,661	1,112	1,125	0,612	0,619	5,33
45	7,976	7,983	4,661	1,110	1,123	0,640	0,648	5,97
50	8,992	8,999	6,413	1,628	1,640	0,840	0,848	6,22
55	11,405	11,412	7,684	2,176	2,189	0,845	0,853	6,48
60	13,488	13,495	7,684	2,153	2,164	1,158	1,165	7,92
70	15,774	15,781	10,262	2,545	2,557	1,285	1,292	8,71
80	17,831	17,838	11,76	2,608	2,621	1,628	1,635	9,52
90	20,257	20,264	12,827	3,111	3,121	1,648	1,656	10,31
100	22,467	22,473	15,24	4,006	4,018	1,839	1,847	11,1

3.3.2 Gauging the fallaway of dimension B

See Figure 5.

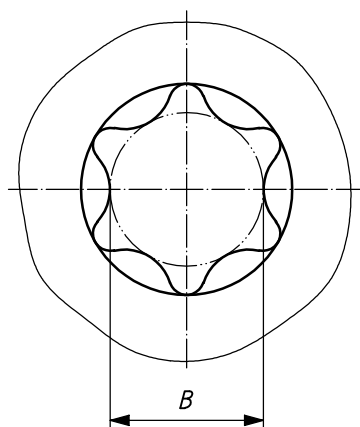

Figure 5 — Cylindrical zone to be gauged

A cylindrical NO GO gauge with diameter as specified in Table 5 shall not enter the hexalobular internal driving feature to a depth greater than the fallaway allowance specified in Table 2.

Table 5 — Diameter of cylindrical NO GO gauge for dimension *B*

Dimensions in millimetres

Socket No.	Diameter of cylindrical NO GO gauge	
	min.	max.
6	1,440	1,445
8	1,920	1,925
10	2,280	2,285
15	2,760	2,765
20	3,280	3,285
25	3,720	3,725
30	4,660	4,665
40	5,600	5,605
45	6,660	6,665
50	7,380	7,385
55	9,660	9,665
60	11,340	11,345
70	13,340	13,345
80	14,920	14,925
90	17,160	17,165
100	19,020	19,025

4 Designation

The designation shall make reference to this International Standard and the socket number.

EXAMPLE A hexalobular internal driving feature, socket No. 20, is designated as follows:

Hexalobular internal driving feature ISO 10664 - 20

Annex A (informative)

Representation of hexalobular internal driving feature contour

The correlations of dimensions given in Figure A.1 are intended to support the drawing of the driving feature only, e.g. when using a CAD system.

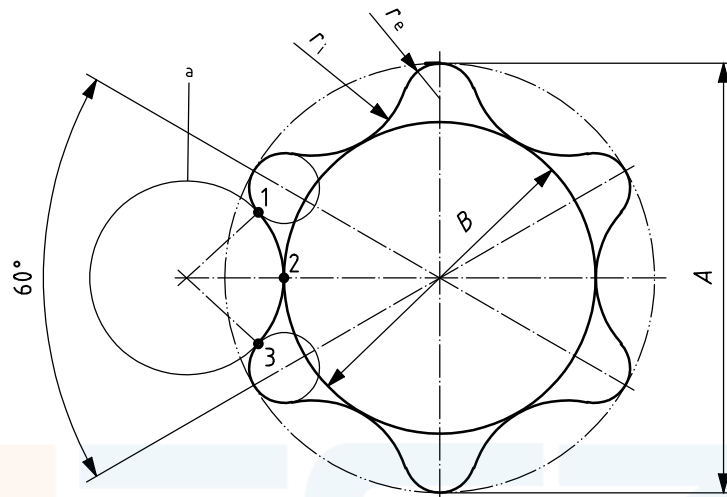

$$B \approx 0,72 A$$

$$r_e \approx 0,1 A$$

$$r_i \approx 0,175 A$$

^a The circle is tangential to the socket contour at points 1, 2 and 3.

Figure A.1 — Representation of hexalobular internal driving feature



ICS 21.060.10

Price based on 7 pages