

22 B 级六角头法兰面螺栓 (GB/T 5787—1986)

B 级六角头法兰面螺栓的尺寸规格和质量见表 4.1-41 和表 4.1-42。

表 4.1-41 B 级六角头法兰面螺栓的尺寸规格 (mm)

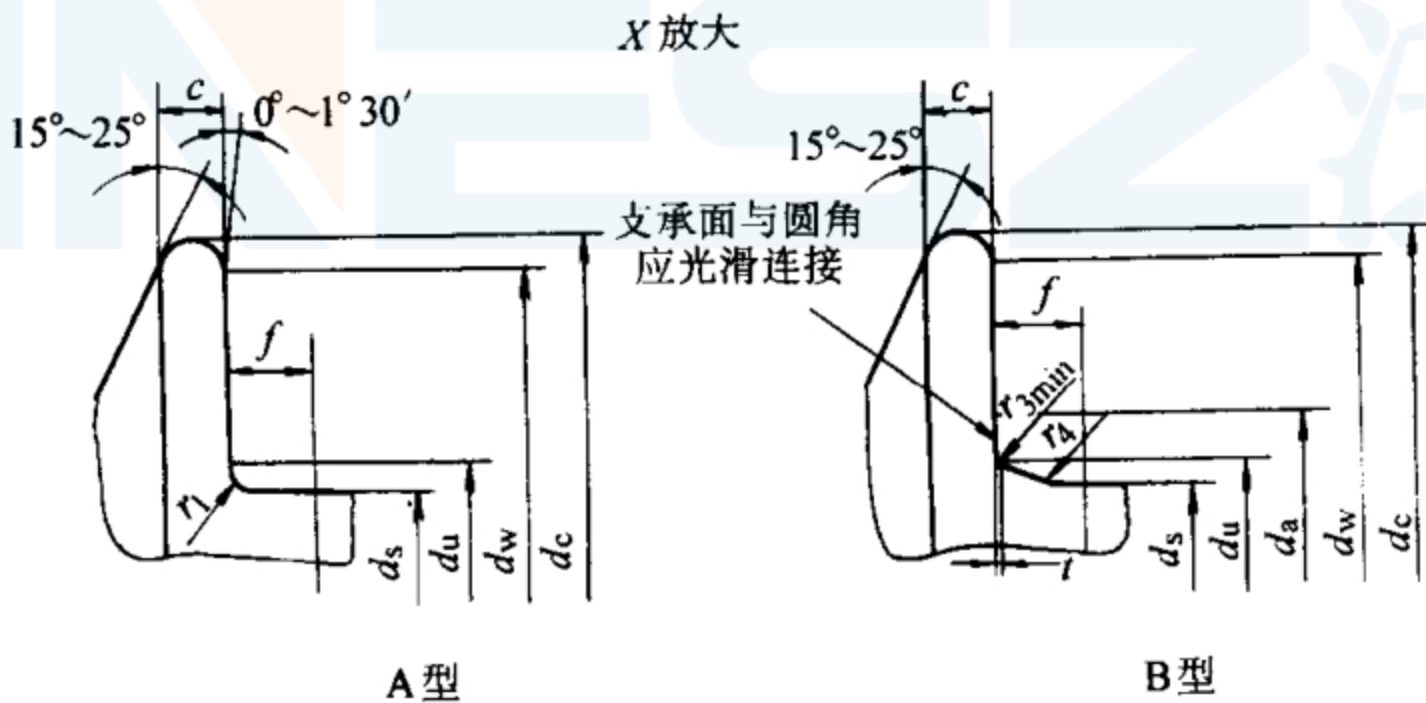
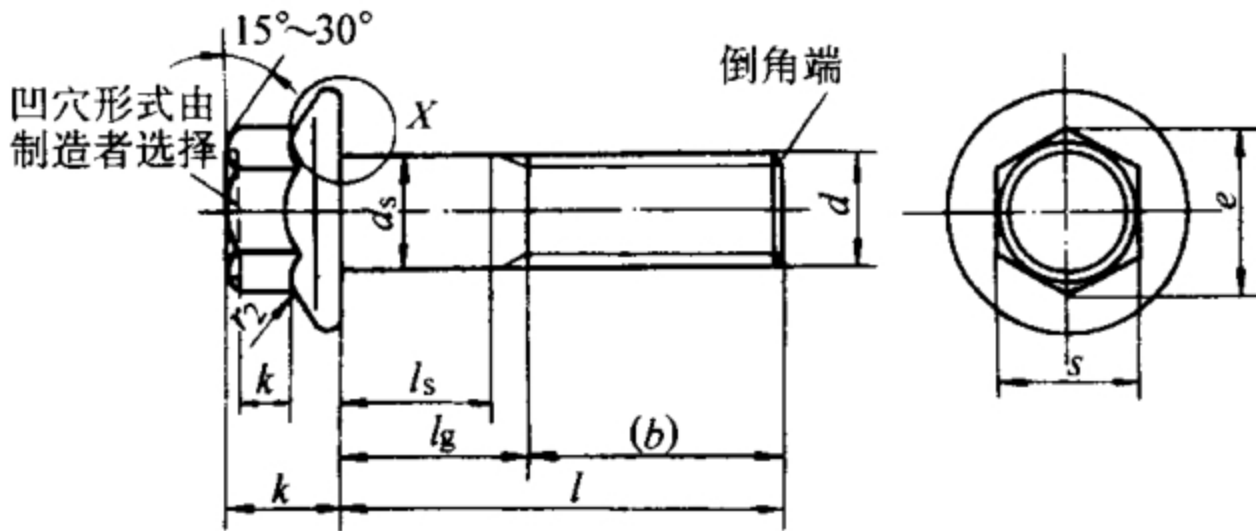

$$l_{g\max} = l_{\text{公称}} - b_{\text{参考}}, \quad l_{g\min} = l_{g\max} - 5P, \quad P \text{ —— 螺距}$$

螺纹规格 d		M5	M6	M8	M10	M12	(M14)	M16
b 参考	$l \leq 125$	16	18	22	26	30	34	38
	$120 < l \leq 200$	—	—	28	32	36	40	44
c	min	1	1.1	1.2	1.5	1.8	2.1	2.4

续表 4.1-41

螺纹规格 d		M5	M6	M8	M10	M12	(M14)	M16
d_a	A 型	5.7	6.8	9.2	11.2	13.7	15.7	17.7
	B 型	6.2	7.4	10	12.6	15.2	17.7	20.7
d_c	max	11.4	13.6	17	20.8	24.7	28.6	32.8
d_s	max	5	6	8	10	12	14	16
	min	4.82	5.82	7.78	9.78	11.73	13.73	15.73
d_u	max	5.5	6.6	9	11	13.5	15.5	17.5
d_w	min	9.4	11.6	14.9	18.7	22.6	26.4	30.6
e	min	7.44	8.56	10.8	14.08	16.32	19.68	22.58
f	max	1.4	2	2	2	3	3	3
k	max	5.6	6.8	8.5	9.7	11.9	12.9	15.1
k'	min	2.3	2.9	3.8	4.3	5.4	5.6	6.7
r_1	min	0.2	0.25	0.4	0.4	0.6	0.6	0.6
r_2	max	0.3	0.4	0.5	0.6	0.7	0.9	1
r_3	min	0.1	0.1	0.15	0.2	0.25	0.3	0.35
r_4	参考	3	3.4	4.3	4.3	6.4	6.4	6.4
s	max	7	8	10	13	15	18	21
	min	6.64	7.64	9.64	12.57	14.57	17.57	20.16
t	max	0.15	0.2	0.25	0.3	0.35	0.45	0.5
	min	0.05	0.05	0.1	0.15	0.15	0.2	0.25
$l^{\text{①}}$		10 ~ 50	12 ~ 60	16 ~ 80	20 ~ 100	25 ~ 120	30 ~ 140	35 ~ 160

注：尽可能不采用括号内的规格。

① l 公称长度系列：10、12、16、20~70（5进级）、80~160 mm（10 mm进级）。

表 4.1-42 B 级六角头法兰面螺栓的质量 (kg)

每 1 000 件钢制品的大约质量									
<i>l</i>	<i>G</i>	<i>l</i>	<i>G</i>	<i>l</i>	<i>G</i>	<i>l</i>	<i>G</i>	<i>l</i>	<i>G</i>
M5		M6		M10		M12		M16	
10	2.66	60	14.02	45	32.14	90	85.69	35	82.14
12	2.90	M8		50	35.06	100	94.12	40	88.69
16	3.38	16	9.72	(55)	37.99	110	102.6	45	95.23
20	3.87	20	10.96	60	40.92	120	111.0	50	101.8
25	4.58	25	12.52	(65)	43.85	(M14)		55	108.3
30	5.29	30	14.07	70	46.78	30	62.37	60	117.3
35	6.00	35	16.03	80	52.64	35	68.91	65	124.9
40	6.71	40	17.89	90	58.50	40	75.45	70	132.5
45	7.42	45	19.74	100	64.36	45	81.99	80	147.7
50	8.14	50	21.59	M12		50	88.54	90	162.8
M6		(55)	23.45	25	32.70	(55)	93.39	100	178.0
12	4.46	60	25.30	30	36.26	60	99.16	110	193.1
16	5.14	(65)	27.16	35	39.82	(65)	104.9	120	208.3
20	5.83	70	29.01	40	43.38	70	110.7	130	222.2
25	6.68	80	32.72	45	47.76	80	122.3	140	237.4
30	7.79	M10		50	51.98	90	133.8	150	252.5
35	8.83	20	18.77	(55)	56.19	100	145.4	160	267.7
40	9.87	25	21.22	60	60.41	110	156.9		
45	10.91	30	23.68	(65)	64.62	120	168.5		
50	11.94	35	26.13	70	68.83	130	180.9		
(55)	12.98	40	29.21	80	77.26	140	192.5		

注：尽量不采用括号内的规格。